

# SYNERGY TELECOM PVT LTD

Synergy Telecom Pvt Ltd is a leading provider and manufacturer of Telecom Equipment, Antennae, Cable assemblies, Microwave Components, IoT and M2M learning, IBS and BTS installation materials, Solar passive components, and solutions. We focus on research and production and maintain a large inventory of fast-moving materials like Cable, Cable Assemblies, Connectors, Passive RF components, and Installation materials. We are approved vendors of BEL, ITI, DRDO, RAILWAYS, ISRO, Private Telecom Operators, BSNL. We believe in creating value for our customers by continuous improvement of products, service quality, and customer satisfaction. We provide products from dc through microwave and milli-meter wave frequencies to our international commercial and military customers who are involved in high-frequency industries including radar, communications, high energy physics, satellites, industrial heating, medical electronics, etc.

## ▼ Broadband Horn Antennas

### ► Double-ridged

### ► Quad-ridged

#### Feature:

- **Linear/Dual Linear** polarization
- Cover a wide frequency range from **0.1GHz to 110GHz**
- High gain & low VSWR
- Compact
- Competitive
- Customizable

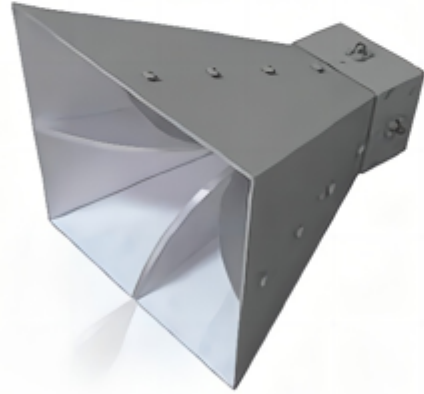

#### Application:

- EMI testing
- Direction finding
- Surveillance
- Antenna gain and pattern measurements
- Other application

Model	Freq. (GHz)	Pol.	Gain. Typ. (dBi)	VSWR Typ	Connector	Power Handling (W) CW	Size (mm)
SL-BDHA 0.1/1-N-F	0.1-1	Linear	8	2.5	N-F	800	2250*2154*1423
SL-BDHA 0.2/2.5-N-F	0.2-2.5	Linear	12	2.0	N-F; 7/16 DIN-F	800	967*731*902
SL-BDHA 0.4/6.0-N-F	0.4-6.0	Linear	10	1.5	N-F	500	532*340*443
SL-BDHA 0.5/50-2.4-F	0.5-50.0	Linear	12	1.8	2.4mm-F	10	368.5*264*5*328
SL-BDHA 1/20-SMA-F	1.0-20.0	Linear	11	1.5	SMA-F	50	244*160*204
SL-BDHA 6/18-N-F	6.0-18.0	Linear	10	1.5	N-F	150	55*56*109
SL-BDHA 6/67-1.85mm-F	6.0-67.0	Linear	13	1.5	1.85mm-F	5	42*42*65
SL-BDHA 18/50-2.4mm-F	18.0-50.0	Linear	20	1.5	2.4mm-F	10	55*55*113
SL-BDHA 10/110-1.0mm-F	10.0-110.0	Linear	13	1.5	1.0mm-F	4	42*42*65
SL-BDHA 18/110-1.0mm-F	18.0-110.0	Linear	14	1.5	1.0mm-F	4	42*42*65
SL-BQHA 6/18-2.4-F	6.0-18.0	Dual Linear	12	1.5	2.4mm-F	10	44.5*44.5*78
SL-BQHA 18/37-1.85-F	18.0-67.0	Dual Linear	15	1.8	1.85mm-F	5	34*34*61.5

## ▼ Octave Horn Antenna

### ► Octave Horn Antenna

### ► Multi-Octave Horn Antenna

#### Feature:

- **Linear** polarization
- Cover a frequency range from **0.84GHz to 26.5GHz**
- High gain & low VSWR
- Compact
- Competitive
- Customizable

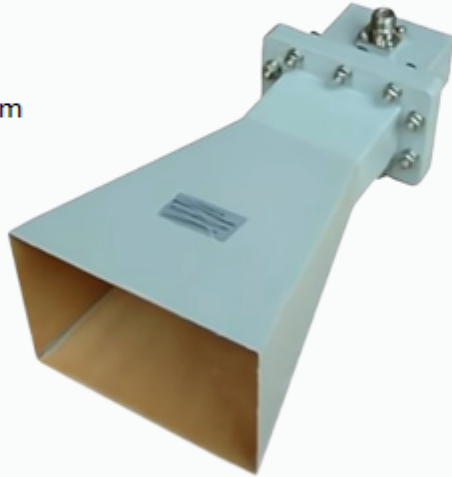

#### Application:

- EMI testing
- Direction finding
- Surveillance
- Antenna gain and pattern measurements
- Other application

Model	Freq. (GHz)	Pol.	Gain. Typ. (dBi)	VSWR Typ	Connector	Power Handling (W) CW	Size (mm)
SL-OHA 1/2-N-F	1.0-2.0	Linear	10	1.5	N-F	300	315*235*428
SL-OHA 1/2-SMA-F	1.0-2.0	Linear	15	1.5	SMA-F	50	564*424*650
SL-OHA 2/4-SMA-F	2.0-4.0	Linear	10	1.5	SMA-F	50	165*125*257
SL-OHA 2/4-N-F	2.0-4.0	Linear	15	1.5	N-F	300	264*204*377
SL-OHA 4/8-3.5-F	4.0-8.0	Linear	15	1.5	3.5mm-F	50	139*103*230
SL-OHA 4/8-7-F	4.0-8.0	Linear	20	1.5	7mm-F	150	225-173*315
SL-OHA 6/12-N-F	6.0-12.0	Linear	15	1.5	N-F	150	172*128*270
SL-OHA 6/12-SMA-F	6.0-12.0	Linear	20	1.5	SMA-F	50	172*128*270
SL-MOHA 0.84/2-N-F	0.84-2.0	Linear	15	1.5	N-F	500	586*436*769
SL-MOHA 6/16-SMA-F10	6.0-16.0	Linear	10	1.5	SMA-F	50	46*30*120
SL-MOHA 11/26.5-SMA-F	11.0-26.5	Linear	15	1.5	SMA-F	50	52*42*112

## ▼ Dual Polarization Horn Antenna

### ► Broadband Dual Polarization Horn Antenna

### ► Conical Dual Polarization Horn Antenna

### ► Open Boundary Quad-ridged Dual Polarization Horn Antenna

#### Feature:

- **Dual polarization**
- Cover a frequency range form **0.4GHz to 50.0GHz**
- High gain & low VSWR
- Durable for both indoor and outdoor environment
- Customizable



#### Application:

- EMI testing
- Direction finding
- Surveillance
- Antenna gain and pattern measurements
- Other application

Model	Freq. (GHz)	Pol.	Gain. Typ. (dBi)	VSWR Typ	Connector	Power Handling (W) CW	Size (mm)
SL-OBQR 0.4/6-SMA-F	0.4-6.0	Dual Linear	12	1.5	SMA-F	50	510*510*550
SL-OBQR 0.7/6-N-F	0.7-6.0	Dual Linear	11	2	N-F	50	510*510*550
SL-OBQR 0.7/10-SMA-F	0.7-10.0	Dual Linear	11	2	SMA-F	50	310*310*412
SL-OBQR 0.7/12-N-F	0.7-12.0	Dual Linear	12	2	N-F	50	265.5*265.5*258.5
SL-OBQR 0.7/12-SMA-F	0.7-12.0	Dual Linear	12	2	SMA-F	50	265.5*265.5*258.5
SL-OBQR 1/18-N-F	1.0-18.0	Dual Linear	10	2	N-F	50	190.5*190.5*186.5
SL-OBQR 1/18-SMA-F	1.0-18.0	Dual Linear	10	2	SMA-F	50	190.5*190.5*186.5
SL-OBQR 1/20-N-F	1.0-20.0	Dual Linear	10	2	N-F	50	190.5*190.5*186.5
SL-OBQR 1/20-SMA-F	1.0-20.0	Dual Linear	10	2	SMA-F	50	190.5*190.5*186.5
SL-OBQR 2/50-2.4-F	2.0-50.0	Dual Linear	13	2	2.4mm-F	10	90*53*53
SL-OBQR 2/50-1.85-F	2.0-50.0	Dual Linear	10	2	1.85mm-F	5	90*53*53
SL-MOHA 0.84/2-N-F	0.84-2.0	Linear	15	1.5	N-F	500	586*436*769
SL-MOHA 11/26.5-SMA-F	11.0-26.5	Linear	15	1.5	SMA-F	50	52*42*112

#### Options for Dual Polarization Horn Antenna

Option1	Convert to LHCP
Option2	Convert to RHCP
Option3	Convert to Dual Circular
Option4	Convert to Vertical, Horizontal, LHCP, RHCP, Switchable

## ▼ Standard Gain Horn Antenna

### ▶ 10dB Standard Gain Horn Antenna

### ▶ 15dB Standard Gain Horn Antenna

### ▶ 20dB Standard Gain Horn Antenna

### ▶ 25dB Standard Gain Horn Antenna

#### Feature:

- **Linear** polarization
- Cover a frequency range form **0.32GHz to 500.0GHz**
- High gain & low VSWR
- Compact design
- Competitive
- Customizable

#### Application:

- EMI testing
- Direction finding
- Surveillance
- Antenna gain and pattern measurements
- Other application

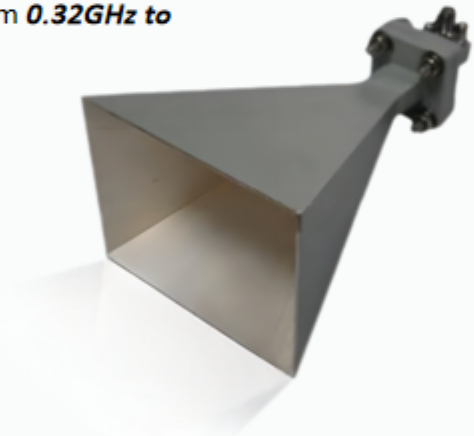

Model	Freq. (GHz)	Pol.	Gain. Typ. (dB)	VSWR Typ	Waveguide	Output	Mat.
SL-SGHA10 0.32/0.49-F3	0.32-0.49	Linear	10	1.15	WR2300	FDP3	Al
SL-SGHA10 15/22-F180	15.0-22.0	Linear	10	1.15	WR51	FBP180	Cu
SL-SGHA10 22/33-F260	22.0-33.0	Linear	10	1.15	WR34	FBP260	Cu
SL-SGHA10 75/110-F900	75.0-110.0	Linear	10	1.15	WR10	FUGP900	Cu
SL-SGHA10 110/170-UM	110.0-170.0	Linear	10	1.2	WR6	UG387/U-M	Cu
SL-SGHA15 0.75/1.12-F9	0.75-1.12	Linear	15	1.15	WR975	FDP9	Al
SL-SGHA15 1.12/1.7-F14	1.12-1.7	Linear	15	1.15	WR650	FDP14	Al
SL-SGHA15 24/50-2.4F	24.0-50.0	Linear	15	1.25	WR28	2.4F; 1.85F	Cu
SL-SGHA15 40/60-F500	40.0-60.0	Linear	15	1.15	WR19	FUGP500	Cu
SL-SGHA15 60/90-F740	60.0-90.0	Linear	15	1.2	WR12	FUGP740	Cu
SL-SGHA15 90/140-UM	90.0-140.0	Linear	15	1.1	WR8	UG387/U-M	Cu
SL-SGHA20 1.12/1.7-F14	1.12-1.7	Linear	20	1.15	WR650	FDP14	Al
SL-SGHA20 1.7/2.6-F22	1.7-2.6	Linear	20	1.15	WR430	FDP22	Al
SL-SGHA25 140/220-UM	140.0-220.0	Linear	25	1.2	WR5	UG387/U-M	Cu
SL-SGHA25 220/325-A3	220.0-325.0	Linear	25	1.15	WR3	APF3	Cu
SL-SGHA25 325/500-A2.2	325.0-500.0	Linear	25	1.15	WR2.2	APF2.2	Cu

## ▼ Diagonal Horn Antenna

### Feature:

- **Linear** polarization
- Cover a frequency range form **0.75GHz to 220.0GHz**
- extremely low side-lobes
- Compact design
- Competitive
- Customizable

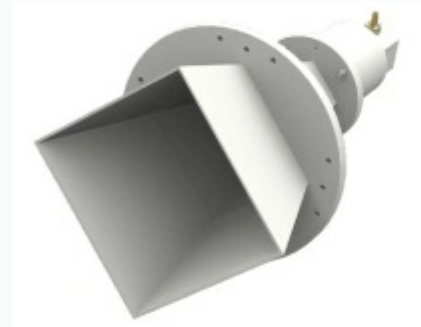

### Application:

- Anechoic chamber illumination
- Antenna far field test
- Radar cross section(RCS) measurement
- Other application

Model	Freq. (GHz)	Pol.	Gain. Typ. (dB)	EIA WG	Output	Mat.
SL-DHA 0.75/1.12-F9	0.75-1.12	Linear	15	WR975	FDP9(UDR9); NF; SF; 7/16F	Al
SL-DHA 1.12/1.7-F14	1.12-1.7	Linear	15	WR650	FDP14(UDR14); NF; SF; 7/16F	Al
SL-DHA 1.7/2.6-F22	1.7-2.6	Linear	15	WR430	FDP22(UDR22); NF; SF; 7/16F	Al
SL-DHA 2.6/3.95-F32	2.6-3.95	Linear	20	WR284	FDP32(UDR32); NF; SF; 7/16F	Al
SL-DHA 3.95/5.85-F48	3.95-5.85	Linear	25	WR187	FDP48(UDR48); NF; SF; TF; 7mm; 3.5F	Al
SL-DHA 8.2/12.4-100F	8.2-12.4	Linear	25	WR90	FDP100(UBR100); SF; NF; TF; 7mm; 3.5F	Al
SL-DHA 12.4/18.0-F140	12.4-18.0	Linear	25	WR62	FDP140(UBR140); SF; NF; TF; 7mm; 3.5F	Al
SL-DHA 18/26.5-F220	18.0-26.5	Linear	25	WR42	FDP220(UBR220); SF; KF; 3.5F	Al
SL-DHA 26.5/40-F320	26.5-40.0	Linear	25	WR28	FDP320(UBR320); KF; 2.4F	Cu
SL-DHA 40/60-F500	40.0-60.0	Linear	25	WR19	FUGP500(UG-383/U-M); 1.85F	Cu
SL-DHA 50/75-F620	50.0-75.0	Linear	25	WR15	FUGP620(UG-385/U)	Cu
SL-DHA 60/90-F740	60.0-90.0	Linear	25	WR12	FUCP740(UG-387/U)	Cu

## ▼ Conical Horn Antenna

### ► Conical Horn Antenna

### ► Corrugated Conical Horn Antenna

### ► Corrugated Feed Horn Horn Antenna

#### Feature:

- *Linear/Circular/Dual Linear* polarization
- Cover a frequency range form **0.75GHz to 260.0GHz**
- Compact design
- Competitive
- Customizable

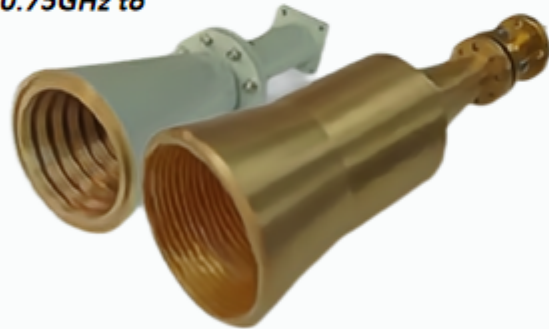

#### Application:

- Antenna far field test
- RF radiation measurements
- Other application

Conical Horn Antenna with Other Circular WG Interface

Model	Freq. (GHz)	Pol.	Gain. Typ. (dB)	Flange	Mat.
-	8.2-12.4	Linear& Circular	10; 15; 20	FBP100-M	Al
-	10.0-15.0	Linear& Circular	15; 20; 25	FBP120-M	Al
-	12.4-14.6	Linear& Circular	15; 20; 25	FBP140-M	Al
-	14.6-17.5	Linear& Circular	15; 20; 25	FBP180-M	Al
-	125.0-140.0	Linear& Circular	15; 20; 25	UG-387/U-M	Cu
-	140.0-160.0	Linear& Circular	15; 20; 25	UG-387/U-M	Cu
-	183.0-240.0	Linear& Circular	15; 20; 25	UG-387/U-M	Cu

Conical Horn Antenna with Integrated Rectangular WG Transition-Linear

Model	Freq. (GHz)	Pol.	Gain. Typ. (dB)	Flange	Figure	Mat.	Size (mm)
SL-CHIRW 26.5/40-F320	26.5-40.0	Linear	20	FBP320	A Type	Cu	46*46*52
SL-CHIRW 26.5/40-2.92F	26.5-40.0	Linear	20	2.92mm-F	C Type	Cu	46*46*52
SL-CHIRW 26.5/40-2.4F	26.5-40.0	Linear	20	2.4mm-F	C Type	Cu	46*46*52
SL-CHIRW 50/75-F620	50.0-75.0	Linear	20	FUGP620	A Type	Cu	25*25*28
SL-CHIRW 50/65-1.85F	50.0-65.0	Linear	20	1.85mm-F	C Type	Cu	25*30*56
SL-CHIRW 50/75-1.0F	50.0-75.0	Linear	20	1.0mm-F	C Type	Cu	25*28*53.5

## ▼ Lens Horn Antenna

### ► Lens Horn Antenna

### ► Spot-focusing Lens Horn Antenna

#### Feature:

- **Linear/Circular/Dual Linear** polarization
- Cover a frequency range from **7.5GHz to 112.0GHz**
- Compact design
- Competitive
- Customizable



#### Application:

- Multipoint Video Distribution Systems
- Local Multipoint distribution services
- Traffic Control Systems
- Secure Communications Systems
- Electro-Magnetic Compatibility(EMC)

#### Measurements

- Point to Point Radio Links
- Other application

#### Lens Horn Antenna

Model	Freq. (GHz)	Pol.	EIA WR	Gain. Typ. (dB)	VSWR Typ.	Output
SL-LHA 7.9/8.5-F84	7.9-8.5	Linear	WR112	25	1.5	FBP84
SL-LHA 8.2/12.4-F100	8.2-12.4	Linear	WR90	25	1.6	FBP100
SL-LHA 21.2/26.5-F220	21.2-26.5	Linear	WR42	34.5	1.5	FBP220
SL-LHA 26.5/40-F320	26.5-40.0	Linear	WR28	33	1.3	FBP320
SL-LHA 50/75-F620	50.0-75.0	Linear	WR15	34.5	1.5	FUGP620

#### Spot-focusing Lens Horn Antenna

Model	Freq. (GHz)	Pol.	Focal Length	Spot Size	EIA WR	VSWR Typ.	Output
SL-SLHA 7.5/18-F24	7.5-18.0	Linear	320; 440	50; 75	WRD750	2.2; 1.8	FPWRD750D 24
SL-SLHA 26.5/40-F320	26.5-40.0	Linear	150; 220; 270	20; 10; 25	WR28	1.25; 1.5; 1.5	FBP320
SL-SLHA 60/90-F740	60.0-90.0	Linear	170; 210	20; 22	WR12	1.5; 1.5	FUGP740



## ▼ Reflector Antenna

### ▶ Cassegrain antenna

### ▶ Primary Focus Parabolic Antenna

#### Feature:

- **Linear/Dual Linear** polarization
- Cover a frequency range from **12.0GHz to 110.0GHz**
- Compact design
- Competitive
- Customizable

#### Application:

- Multipoint Video Distribution Systems
- Local Multipoint distribution services
- Traffic Control Systems
- Secure Communications Systems
- Electro-Magnetic Compatibility(EMC) Measurements
- Point to Point Radio Links
- Other application



#### Cassegrain

Model	Freq. (GHz)	Pol.	EIA WR	Gain. Typ. (dB)	VSWR Typ.	Output
SL-RAC 60/90-F740	60.0-90.0	Linear	WR12	45	1.15	FUGP740
SL-RAC 75/110-F900	75.0-110.0	Linear	WR10	48	1.15	FUGP900

#### Primary Focus Parabolic Antenna

Model	Freq. (GHz)	Pol.	Cross Pol. Isolation Typ(dB)	VSWR Typ.	Output
SL-PFPA 12/16-DL	12.0-16.0	Dual Linear	12	3.0	Coaxial

## ▼ Cavity Backed Spiral Antenna

### Feature:

- **Circular** polarization
- Cover a frequency range form **0.5GHz to 40.0GHz**
- Compact design
- Competitive
- Customizable

### Application:

- EMC testing
- surveillance
- Direction finding
- Telemetry
- flush mounted airborne application
- Other application



Model	Freq. (GHz)	Pol.	Gain. Typ. (dB)	Axial Ratio Max (dB)	VSWR Typ.	Connector	Mat.
SL-CBSA 0.5/2-SF	0.5-2.0	Circular	-6	3	1.5	SMA-F	Al
SL-CBSA 0.8/8-SF	0.8-8.0	Circular	0	3.5	1.5	SMA-F	Al
SL-CBSA 1/18-SF	1.0-18.0	Circular	4	3	2.0	SMA-F	Al
SL-CBSA 18/40-2.92F	18.0-40.0	Circular	2	5.5	2.0	2.92mm-F	Al

## ▼ Conical Log Spiral Antennas

### Feature:

- *Circular* polarization
- Cover a frequency range form **0.2GHz to 10.0GHz**
- Compact design
- Durable
- Customizable

### Application:

- Antenna measurement
- Far-field measurement
- Reflector feed
- System integration
- Other application



Model	Freq. (GHz)	Pol.	Gain. Typ. (dBic)	VSWR Typ.	Connector	Mat.
SL-CLSA 0.2/1-NF	0.2-1.0	LHCP	2	3.0	N-F	Al
SL-CLSA 0.2/1-NF	0.2-1.0	RHCP	2	3.0	N-F	Al
SL-CLSA 1/10-NF	1.0-10.0	LHCP	3	3.0	N-F	Al
SL-CLSA 1/10-NF	1.0-10.0	RHCP	3	3.0	N-F	Al

## ▼ Helical Antennas

### Feature:

- *Circular* polarization
- Cover a frequency range form **6.6GHz to 7.0GHz**
- Low VSWR
- Durable
- Customizable

### Application:

- Antenna measurement
- Far-field measurement
- System integration
- Other application



Model	Freq. (GHz)	Pol.	Gain. Min. (dBic)	VSWR Max	Power Handling (W) CW	Connector
SL-HA 6.6/7-SF	6.6-7.0	LHCP	10	2.0	10	SMA-F
SL-HA 6.6/7-SF	6.6-7.0	RHCP	10	2.0	10	SMA-F
SL-HA 8/8.4-SF	8.0-8.4	LHCP	12	2.0	10	SMA-F
SL-HA 8/8.4-SF	8.0-8.4	RHCP	12	2.0	10	SMA-F
SL-HA 9/10-SF	9.0-10.0	LHCP	12	2.0	10	SMA-F
SL-HA 9/10-SF	9.0-10.0	RHCP	12	2.0	10	SMA-F

## ▼ Log Periodic Antenna

### Feature:

- *Linear/Dual Linear* polarization
- Cover a frequency range form **0.03GHz to 6.0GHz**
- High front-to-back ratio
- lightweight
- Customizable

### Application:

- Gain reference
- Antenna measurement
- Reflector feed
- Chamber evaluation
- Far-field measurement
- System intergration
- Other application



### Log Periodic Antenna-Linear

Model	Freq. (GHz)	Pol.	Gain. Typ. (dBic)	VSWR Typ.	Connector	Mat.
SL-LPAL 0.03/1-NF	0.03-1.0	Linear	6	2.0	N-F	Al
SL-LPAL 0.04/2-NF	0.04-2.0	Linear	6	2.0	N-F	Al
SL-LPAL 0.5/8-NF	0.5-8.0	Linear	7	2.0	N-F	Al
SL-LPAL 0.1/6-NF	0.1-6.0	Linear	7	2.0	N-F	Al

### Log Periodic Antenna-Dual Linear

Model	Freq. (GHz)	Pol.	Gain. Typ. (dBic)	VSWR Typ.	Connector	Mat.
SL-LPADL 0.1/1-NF	0.1-1.0	Dual Linear	7	2.0	N-F	Al
SL-LPADL 0.1/1-NF	0.1-1.0	Dual Linear	7	2.0	N-F	Al
SL-LPADL 0.2/1-NF	0.2-1.0	Dual Linear	7	2.0	N-F	Al
SL-LPADL 0.2/4-NF	0.2-4.0	Dual Linear	7	2.0	N-F	Al

## ▼ Handheld Directional Antenna

### Main specifications:

- 1) Directions of H and E:Heart shape,  
Front-to-rear ratio  $\geq(6-16)$ dB
- 2) Input Impedance: $50\Omega$
- 3) Polarization:Linear(horizontal or vertical)
- 4) VSWR: $<2.5$ (9kHz-20MHz Antenna Module not included)
- 5) Built in amplifier:  
Gain:  $\geq 15$ dB(9KHz -20MHz);  
 $\geq 16$ dB(20MHz -500MHz);  
 $\geq 12$ dB(500MHz -8000MHz)  
P-1:  $\geq +12$ dBm  
IP2:  $\geq +50$ dBm  
IP3:  $\geq +27$ dBm  
Noise Figure: 4.6dB(2GHz)
- 6) Power Supply: + 6V(4 AA batteries)
- 7) Current:100mA
- 8) Connector:N type 9)Total product weight (antenna + portable shipping box): < 7.5 kg



Model	Frequency	Gain(dB)	VSWR	Front-to-rear ratio
SL-HDA-9K/20M	9KHz ~ 20MHz	- 162dBi~30dBi	$\leq 2.5$	> 6dB
SL-HDA-9K/200M	9KHz ~ 200MHz	- 28 dBi~+7 dBi	$\leq 2.5$	> 10dB
SL-HDA-200M/500M	200MHz ~ 500MHz	- 25 dBi~+7 dBi	$\leq 2.5$	> 10dB
SL-HDA-500M/3600M	500MHz ~ 3600MHz	+9 dBi~+18 dBi	$\leq 2.5$	> 10dB
SL-HDA-3600M/8000M	3600MHz ~ 8000MHz	+12dBi~+14dBi	$\leq 2.5$	> 10dB
SL-HDA-500M/8000M	500MHz ~ 8000MHz	+ 2 dBi~+18dBi	$\leq 2.5$	> 6dB

## ▼ Discone-type Antenna

### ► Discone-type Antenna

### ► Bi-conical Antenna

#### Feature:

- **Linear** polarization
- Cover a frequency range from **0.03GHz to 110.0GHz**
- Easy to install
- Customizable

#### Application:

- Surveillance
- Antenna measurement
- System integration
- Other application



#### Discone-type Antenna

Model	Freq. (GHz)	Pol.	Gain. Typ. (dBic)	VSWR Typ.	Connector	Mat.
SL-DA 0.03/0.5-NF	0.03-0.5	Linear	1	2.5	N-F	Al
SL-DA 0.07/1-NF	0.07-1.0	Linear	3	2.0	N-F	Al
SL-DA 0.1/4-NF	0.1-0.4	Linear	0	2.0	N-F	Al
SL-DA 0.25/1-NF	0.25-1.0	Linear	1.5	2.0	N-F	Al
SL-DA 0.8/2-NF	0.8-2.0	Linear	1	2.5	N-F	Al
SL-DA 1/8-NF	1.0-8.0	Linear	4	2.0	SMA-F	Al
SL-DA 1/18-NF	1.0-18.0	Linear	5	2.0	SMA-F	Al

#### Bi-Conical Antenna

Model	Freq. (GHz)	Pol.	Gain. Typ. (dBic)	VSWR Typ.	Connector	Mat.
SL-BCA 0.1/3-NF	0.1-3.0	Linear	4	2.0	N-F	Al
SL-BCA 0.8/4-SF	0.8-4.0	Linear	0	1.5	SMA-F	Al
SL-BCA 2/30-SF	2.0-30.0	Linear	4	2.5	SMA-F	Al
SL-BCA 3/50-2.4F	3.0-50.0	Linear	4	2.0	2.4mm-F	Al
SL-BCA 4/40-2.92F	4.0-40.0	Linear	3	2.0	2.92mm-F	Al
SL-BCA 10/110-1.0F	10.0-110.0	Linear	4	2.0	1.0mm-F	Al

## ▼ Loop Antennas

### Feature:

- **Linear** polarization
- Cover a frequency range from **0.2GHz to 0.5GHz**
- compact design
- Competitive
- Customizable

### Application:

- Gain Reference
- Antenna measurement
- System integration
- Far-field Measurement
- Other application

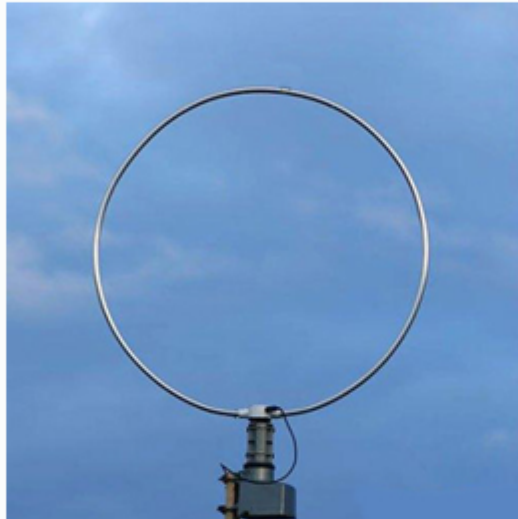

Model	Freq. (GHz)	Gain. Max. (dB)	Gain. Min. (dB)	Pol.	Connector	Size (mm)
SL-LA 0.2/0.5-F100	0.2-0.5	-6	-38	Linear	N	44*292-140



## ▼ Antenna Array & Assembly

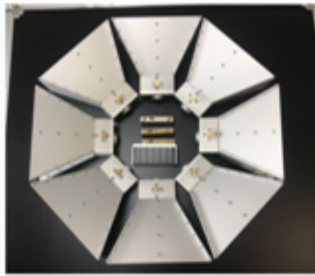

### Microstrip Antenna Array with High Gain

Model	Freq. (GHz)	Gain. Typ. (dB)	Flange	Bandwidth (%)	Size (mm)
SL-MAA 9.4-F100	9.4	22	FBP100	1-3	550*100*10
SL-MAA 1.5-NF	1.5	20	N-F	3-10	1000*800*40
SL-MAA 2.4-SF	2.4	22	SMA-F	3-10	680*220*30
SL-MAA 10.5-SF	10.5	22	SMA-F	3-10	360*120*25
SL-MAA 13.8-SF	13.8	22	SMA-F	3-10	290*95*25

### Microwave monitoring direction finding antenna array

Model	Freq. (GHz)	Gain. Typ. (dB)	VSWR	Coverage	Mat.	Size (mm)
SL-MMDFAA 0.8/18	0.8-18.0	7	2.5	360° ,Pitch - 5° ~+30°	Al/Cu	Φ390*300(wi th radome)

### Direction Finding Antenna

20–3600MHz 5-element Direction Finding Antenna	
<b>Electrical</b>	
Frequency range	Band 1: 20–300 MHz; Band 2: 300–1000 MHz; Band 3: 1000–3600 MHz
Nominal input impedance	50 Ω
Antenna type	5-element DF interferometer
Polarisation	Vertical
Output cables	RG 400 cables (qty 15)
Connectors	TNC male
<b>Mechanical</b>	
Cross-sectional wind load area	0.75 m <sup>2</sup>
Maximum wind speed	150 km/h (without ice)
Weight	44.5 kg
Height	2.582 m ± 10 mm
Diameter (Max)	2.584 m ± 10 mm
Packaging length	1.550 m
Shipping container dimensions	1550 mm x 600 mm x 500 mm

